

aquatica®

Function, Form & Fashion



Sensuality™
Aquastone™ Bathtub

Installation & Care Manual

USA and CANADA

www.aquaticaplumbing.com

E: info@aquaticaplumbing.com

aquatica®
Function, Form & Fashion

Sensuality™ Aquastone™ Bathtub

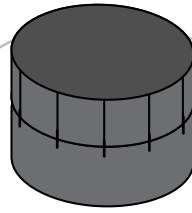
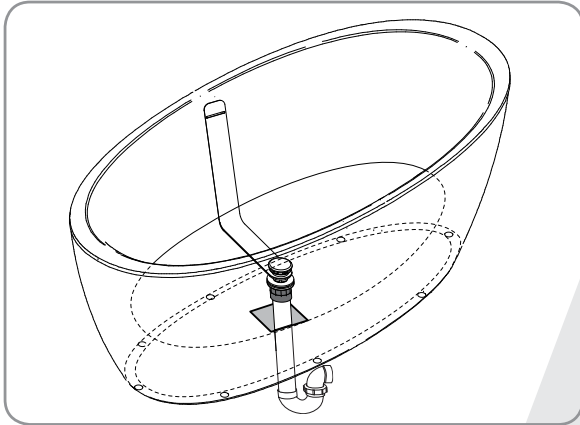

Use Home Depot PART '1 1/2" ABS
Female Adapter Hub x FIPT
or equivalent from another supplier

The ABS female adapter features a hub x female
NPT thread connection and provides a means
for adapting a solvent weld connection
to a threaded connection

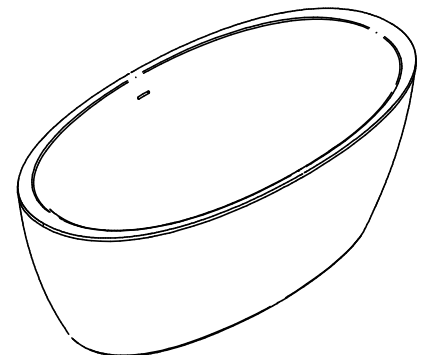
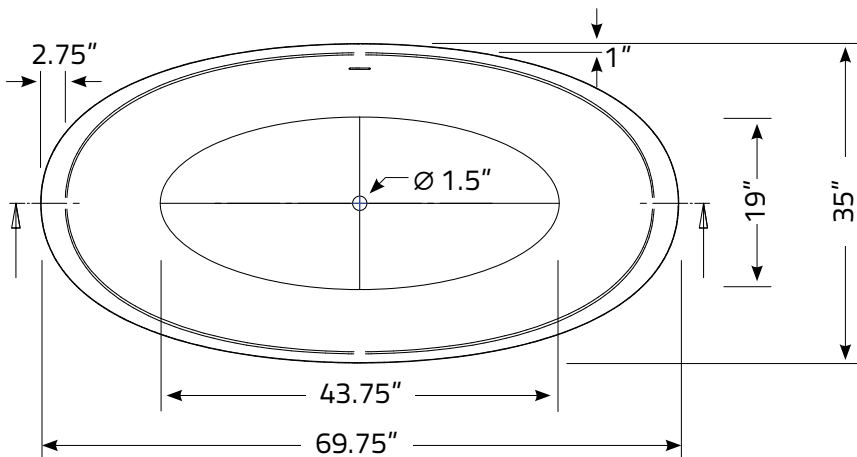
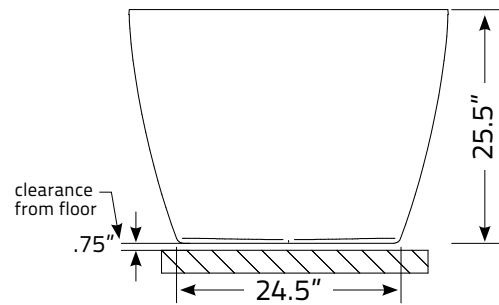
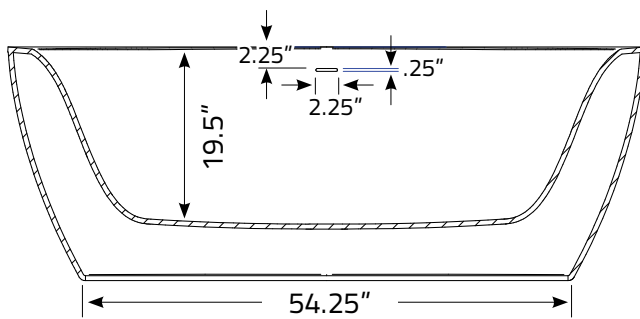
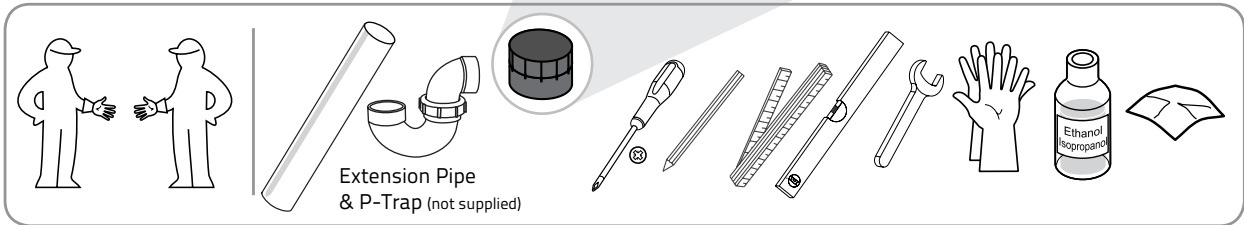

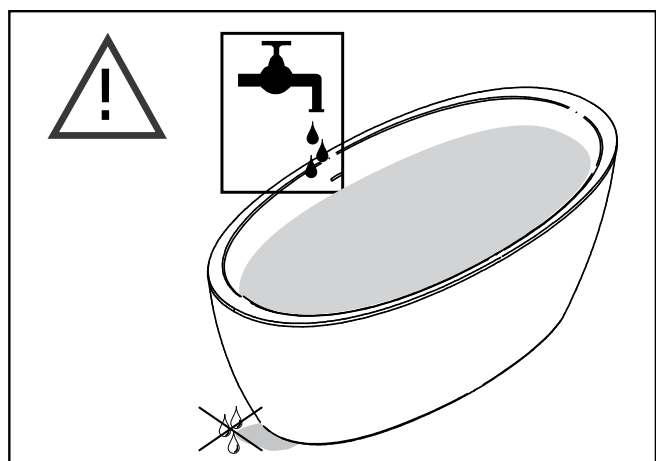
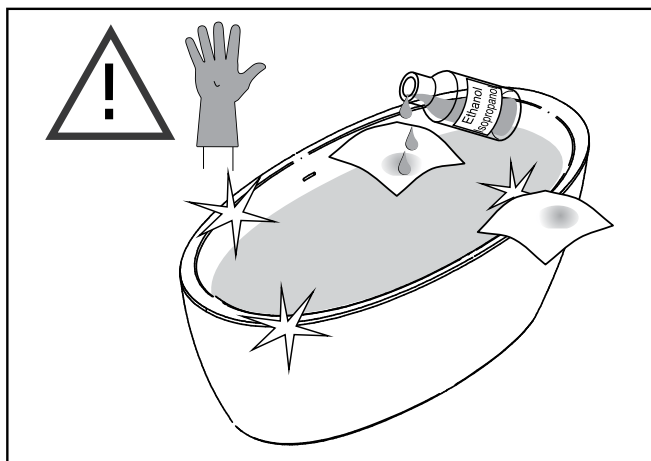
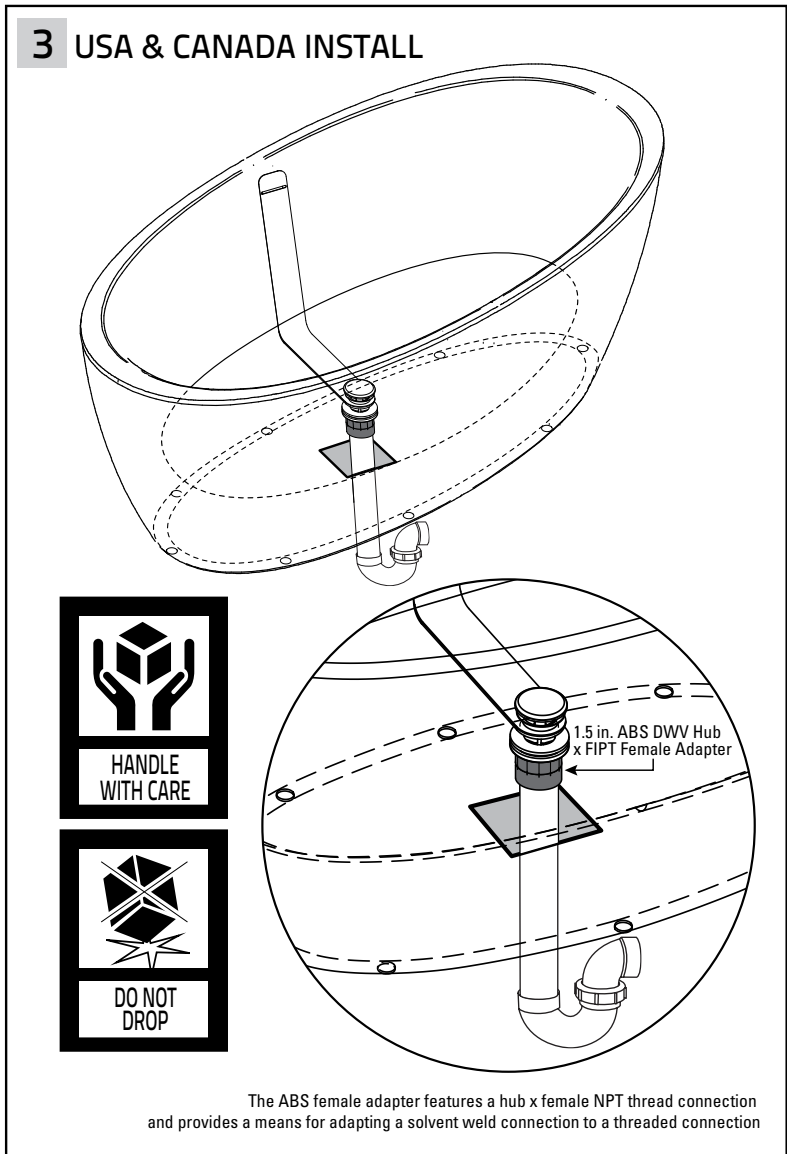
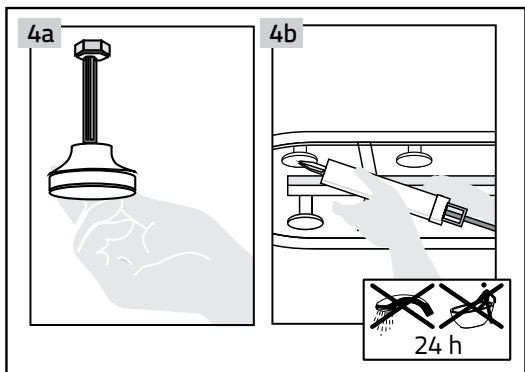
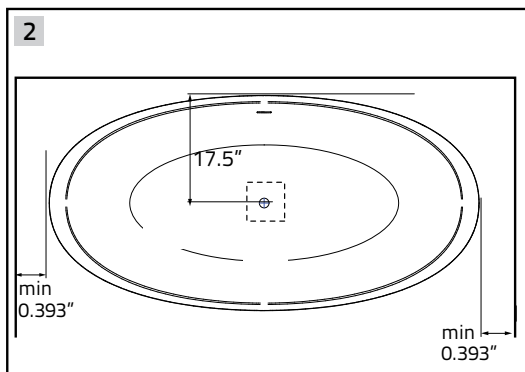
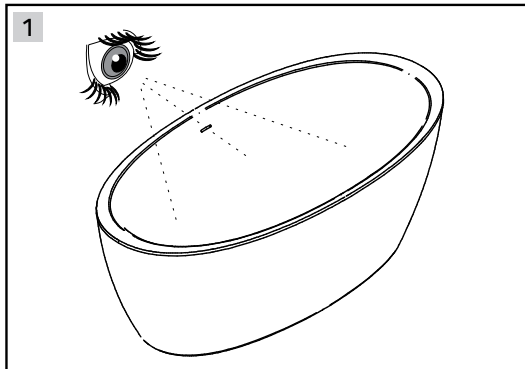

Sensuality™ Aquastone™ Bathtub

TYPICAL FREESTANDING BATHTUB INSTALLATION PROCEDURE

Before you start:

- Ensure that the floor is even.
- The water-overflow fitting is supplied with the product, however other accessories like the slip joint and adaptors are not included and must be purchased separately.
- Because of the technical features of the product, it should be used only with the supplied waste-overflow or specific 3rd party models that have been tested and approved by us.
- Place the bathtub by raising it up 4" with 4x4 pieces of lumber so you can have access from the bottom of the bathtub.
- The bath must rest on its feet, not the monobloc sides. The feet must be adjusted to compensate for any floor imperfections and leave minimal gap with floor.

INSTALLATION SEQUENCE

- The Sensuality™ bathtub is equipped with factory pre-installed overflow system.
- The waste pipe/p-trap connection must be made directly to the waste/drain outlet located at the bottom of the tub.

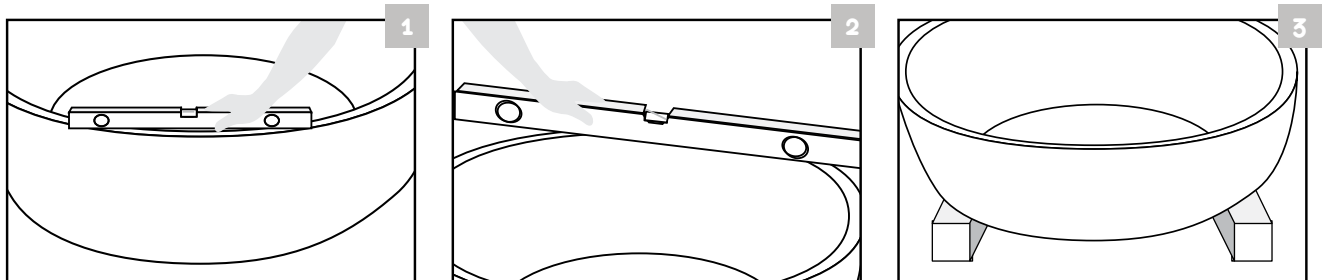

- **Picture 1-2:** the bathtub is leveled via a water level at the intended local installation area.
- **Picture 3:** place the bathtub by raising it up 4" with 4x4 peices of lumber so you can have access from the bottom of the bathtub. **Important note:** during the installation, the bathtub should not be turned on its side to prevent its weight from deflecting its monobloc sides. This is why it is important to use supports to raise the bathtub above the floor. This will also provide you with easy access to the internal plumbing parts.





INSTALLATION SEQUENCE continued

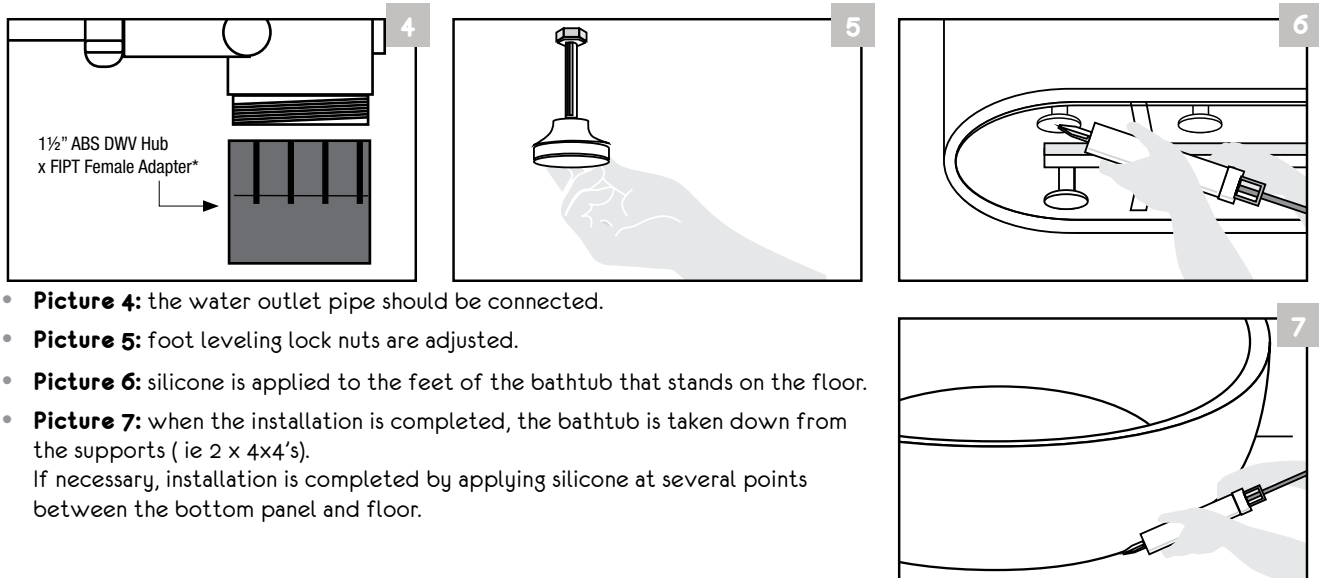

- **Picture 4:** the water outlet pipe should be connected.
- **Picture 5:** foot leveling lock nuts are adjusted.
- **Picture 6:** silicone is applied to the feet of the bathtub that stands on the floor.
- **Picture 7:** when the installation is completed, the bathtub is taken down from the supports (ie 2 x 4x4's).
 If necessary, installation is completed by applying silicone at several points between the bottom panel and floor.

*The ABS female adapter features a hub x female NPT thread connection and provides a means for adapting a solvent weld connection to a threaded connection

INSTALLATION PROCEDURE AT A GLANCE

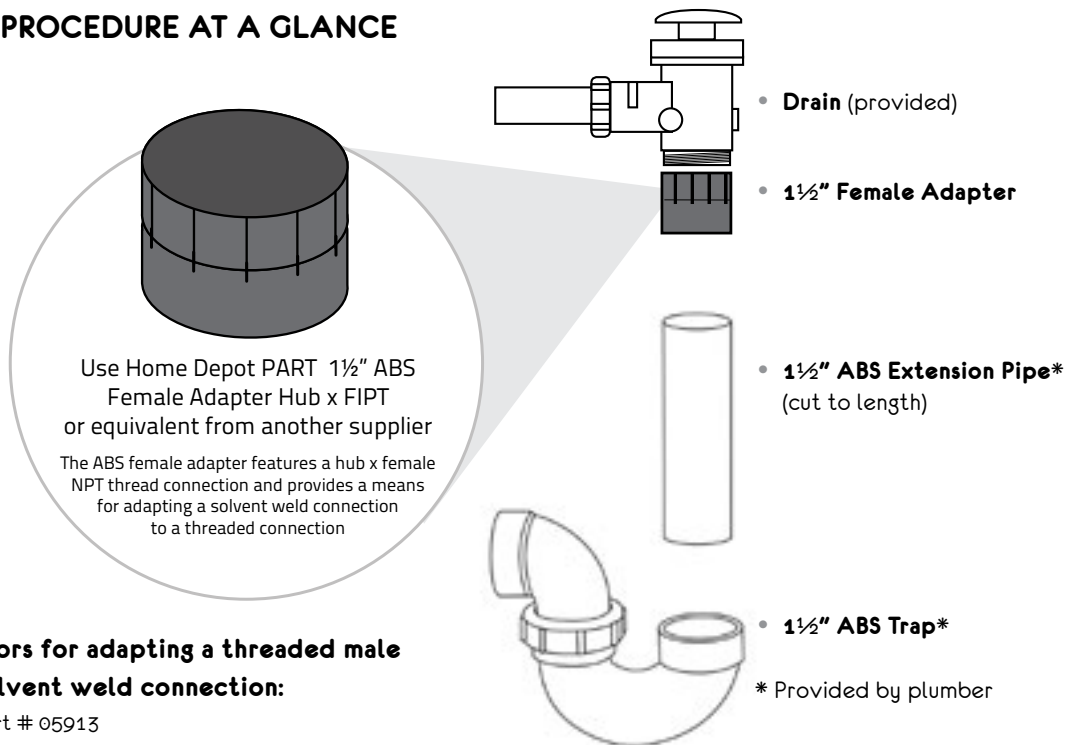

Compatible adaptors for adapting a threaded male connection to a solvent weld connection:

- Mueller Industries: Part # 05913

Or

- Nibco: C4803

<http://www.homedepot.com/p/NIBCO-1-1-2-in-PVC-DWV-Hub-x-FIPT-Female-Adapter-C4803HD112/100677994>

The adaptor must have the appropriate thread type or it will keep slipping and you will not be able to get a tight connection!

Aquatica® Freestanding Bath Installer™

(Kit available separately - not included with bathtub)

FEATURES

- 18 Gauge Epoxy coated Metal Deck Flange
- Designed to be installed in an 8" joist space
- Can be installed with Waterproofing Membrane (*bronte™ NobleSeal TS Recommended)
- CSA Certified for Canadian and US markets

KIT INCLUDES

- 2 Brass tailpieces (Fine Thread and Flanged)
- Freestanding Bath Installer™ assembly with 1-1/2" DWV ABS tailpiece
- Cutting template

INSTALLATION TIPS

- Use 6.5" hole saw to cut sub floor (not included). Cutting template included
- Do not cut the brass tailpiece as this may cause a leak
- Secure Deck Flange with 6 screws (not included)



Certification

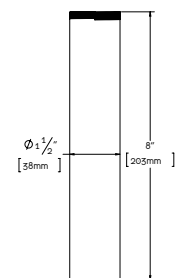
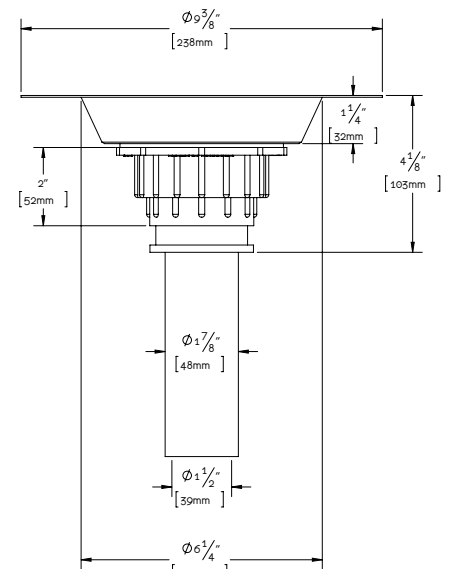

1 1/2" brass tube for female threaded stone bath wastes.

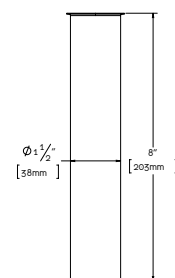

1 1/2" flanged brass tube for Aquatica® cable-drive and concealed bath wastes.

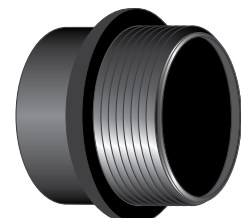

Male Adapter Spg x MIPT - ABS DWV for Aquatica® bath wastes with Sch40 hub outlet.

Thread: 1 1/2" NPSM (1 1/2" IPS)

Aquatica® Freestanding Bath Installer™

(Kit available separately - not included with bathtub)

INSTALLATION INSTRUCTIONS

Attaches to Freestanding Bath W/O

aquatica®

Function, Form & Fashion

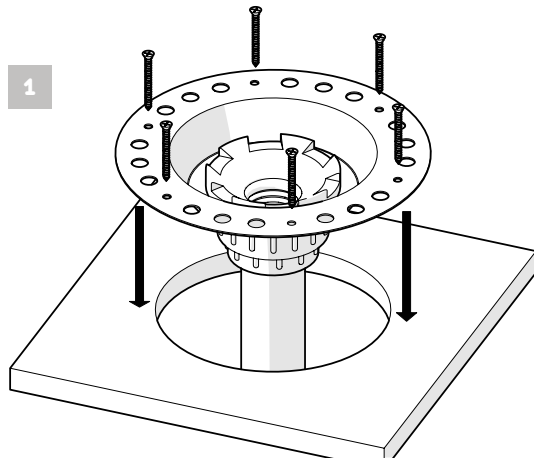

- 1
- A. Cut 6-1/2" (16.5 cm) hole into wood sub-floor (use supplied Cutout Template).
- B. Measure and cut ABS Tailpiece as necessary to ensure a secure connection to P-Trap below.
- C. Insert Freestanding Bath Installer™ assembly into floor opening and connect to Pipe below.
- D. Affix to sub-floor with 6 screws (not supplied)

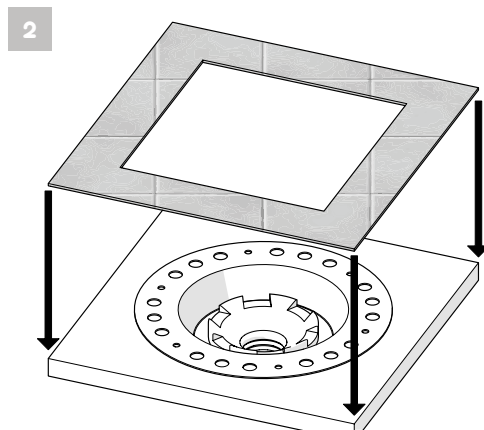

- 2
- A. Install flooring surface, leaving a 6-1/2" opening to access Drain.
- B. Affix the appropriate brass Tailpiece to the Waste & Overflow. NOTE: DO NOT CUT THE BRASS TAILPIECE AS THIS MAY CAUSE A LEAK. Ensure the measurement between the base of the Drain and P-Trap will accommodate the Tailpiece.

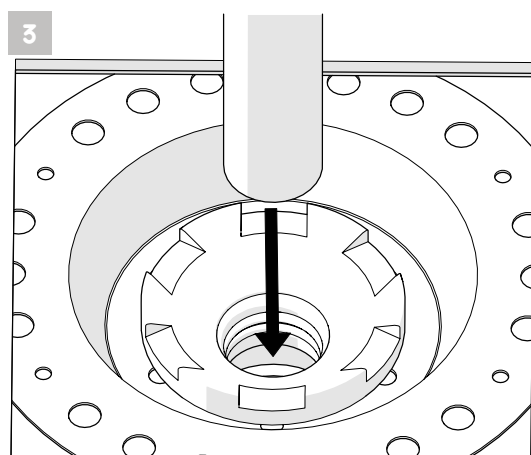

- 3
- A. Cut out the Installation Label with a utility knife and remove to expose the Drain.
- B. Apply lubricant (supplied) to the Tailpiece.
- C. Position the Tub and brass Tailpiece in-line with the Drain.
- D. Carefully lower the tub with the installed brass Tailpiece into the Red Collar in Drain assembly. Ensure Tailpiece is fully engaged with Seal.

IMPORTANT: Do not remove Installation Label until Step 3.

DO NOT CUT THE SUPPLIED BRASS TAILPIECE. Doing so may cause a leak.

Disassembling the drain or cutting the Tailpiece will void the warranty.

aquatica®
Function, Form & Fashion

Sensuality™ - Maintenance Instructions

Sensuality™ - Инструкция по уходу

Sensuality™ - Installation & Entretien

Sensuality™ - Manuale per il corretto mantenimento

Sensuality™ - Instrucciones para la correcta manutención

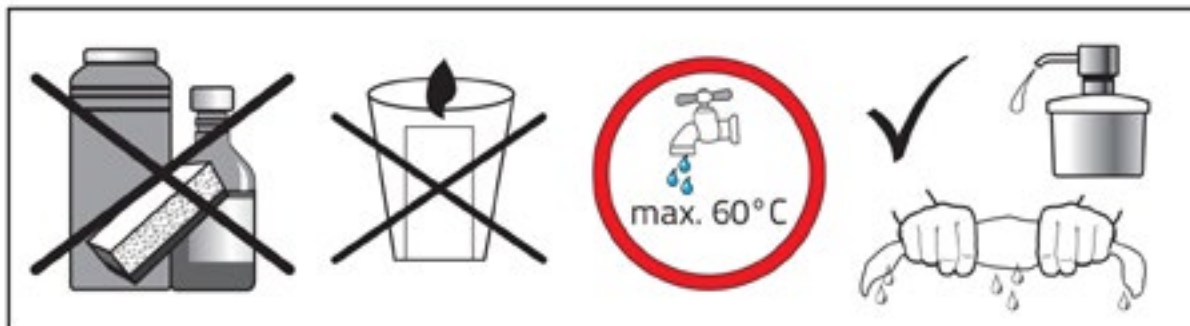

Maintenance Instructions

The smooth surface of your Aquatica® Aquastone™ Bathtub accumulates hardly any dirt, and can be maintained by simply cleaning with a soft cloth, using a mild detergent in water, then wiping over with a dry cloth.

Avoid using abrasive cleansers or solvents, which will cause damage to the surface. Damage caused by use of these products, or any other inappropriate treatment, is not covered by our guarantee.



Инструкция по уходу

Поверхность легко чистится. За счет гладкости грязь к ней не прилипает. Для регулярного ухода используйте мягкую ткань, мыльный раствор и воду. После чистки вытирайте поверхность сухой тканью, которая хорошо впитывает влагу.

Не используйте губки с абразивной поверхностью и агрессивные растворители, которые могут повредить ванну. Повреждения, возникшие вследствие неправильного ухода, не покрываются гарантией.



Installation & Entretien

Cette surface est facile à entretenir et à nettoyer. Sa surface particulièrement lisse, ne retiens que très peu la saleté. Un entretien quotidien nécessite simplement l'utilisation d'un chiffon doux, de l'eau et un peu de savon. Essuyer avec un chiffon sec. L'utilisation de détergents ou de solvants endommageraient cette surface.

Les dommages resultants d'un traitement non conforme effectué par l'utilisateur sont exclus de la garantie que nous offrons.



Manuale per il corretto mantenimento

La superficie necessita di pulizia ed accorgimenti per il corretto mantenimento. Una superficie liscia non accumula lo sporco. Usare una spugnetta con del detergente non aggressivo per una pulizia regolare. Asciugare con un panno. Evitare l'uso di solventi o materiali abrasivi: potrebbero rovinare la superficie.

Un danno causato da trattamento inappropriato non verrà coperto dalla garanzia.



Instrucciones para la correcta manutención

La superficie debe de ser limpiada y adecuadamente mantenida. Una superficie lisa no acumula suciedad.

Utilice una esponja con un detergente suave para la limpieza diaria. Seque con un paño.

No utilice disolventes o materiales abrasivos ya que podrían dañar la superficie.

Los daños causados por el tratamiento inadecuado no serán cubiertos por la garantía.

